

LM392/LM2924

Low Power Operational Amplifier/Voltage Comparator

General Description

The LM392 series consists of 2 independent building block circuits. One is a high gain, internally frequency compensated operational amplifier, and the other is a precision voltage comparator. Both the operational amplifier and the voltage comparator have been specifically designed to operate from a single power supply over a wide range of voltages. Both circuits have input stages which will common-mode input down to ground when operating from a single power supply. Operation from split power supplies is also possible and the low power supply current is independent of the magnitude of the supply voltage.

Application areas include transducer amplifier with pulse shaper, DC gain block with level detector, VCO, as well as all conventional operational amplifier or voltage comparator circuits. Both circuits can be operated directly from the standard 5 V_{DC} power supply voltage used in digital systems, and the output of the comparator will interface directly with either TTL or CMOS logic. In addition, the low power drain makes the LM392 extremely useful in the design of portable equipment.

Advantages

- Eliminates need for dual power supplies
- An internally compensated op amp and a precision comparator in the same package
- Allows sensing at or near ground
- Power drain suitable for battery operation
- Pin-out is the same as both the LM358 dual op amp and the LM393 dual comparator

Features

- Wide power supply voltage range
 - Single supply 3V to 32V
 - Dual supply ±1.5V to ±16V
- Low supply current drain—essentially independent of supply voltage 600 μA
- Low input biasing current 50 nA
- Low input offset voltage 2 mV
- Low input offset current 5 nA
- Input common-mode voltage range includes ground
- Differential input voltage range equal to the power supply voltage

ADDITIONAL OP AMP FEATURES

- Internally frequency compensated for unity gain
- Large DC voltage gain 100 dB
- Wide bandwidth (unity gain) 1 MHz
- Large output voltage swing 0V to V⁺ - 1.5V

ADDITIONAL COMPARATOR FEATURES

- Low output saturation voltage 250 mV at 4 mA
- Output voltage compatible with all types of logic systems

Connection Diagram (Top View)

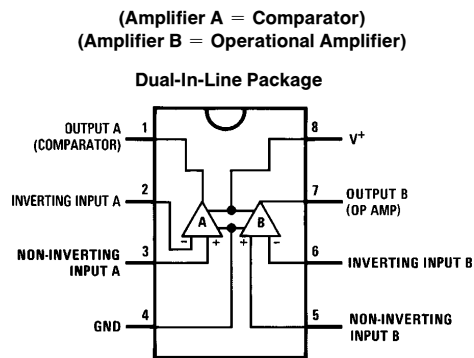

TL/H/7793-1

Order Number LM392M or LM2924M
See NS Package Number M08A
Order Number LM392N or LM2924N
See NS Package Number N08E

Absolute Maximum Ratings

If Military/Aerospace specified devices are required, please contact the National Semiconductor Sales Office/Distributors for availability and specifications.

	LM392	LM2924
Supply Voltage, V^+	32V or $\pm 16V$	26V or $\pm 13V$
Differential Input Voltage	32V	26V
Input Voltage	$-0.3V$ to $+32V$	$-0.3V$ to $+26V$
Power Dissipation (Note 1)		
Molded DIP (LM392N, LM2924N)	820 mW	820 mW
Small Outline Package (LM392M, LM2924M)	530 mW	530 mW
Output Short-Circuit to Ground (Note 2)	Continuous	Continuous
Input Current ($V_{IN} < -0.3 V_{DC}$) (Note 3)	50 mA	50 mA
Operating Temperature Range	$0^\circ C$ to $+70^\circ C$	$-40^\circ C$ to $+85^\circ C$
Storage Temperature Range	$-65^\circ C$ to $+150^\circ C$	$-65^\circ C$ to $+150^\circ C$
Lead Temperature (Soldering, 10 seconds)	$260^\circ C$	$260^\circ C$
ESD rating to be determined.		
Soldering Information		
Dual-in-Line Package		
Soldering (10 seconds)	$260^\circ C$	$260^\circ C$
Small Outline Package		
Vapor Phase (60 seconds)	$215^\circ C$	$215^\circ C$
Infrared (15 seconds)	$220^\circ C$	$220^\circ C$

See AN-450 "Surface Mounting Methods and Their Effect on Product Reliability" for other methods of soldering surface mount devices.

Electrical Characteristics ($V^+ = 5 V_{DC}$; specifications apply to both amplifiers unless otherwise stated) (Note 4)

Parameter	Conditions	LM392			LM2924			Units
		Min	Typ	Max	Min	Typ	Max	
Input Offset Voltage	$T_A = 25^\circ C$, (Note 5)		± 2	± 5		± 2	± 7	mV
Input Bias Current	$IN(+)$ or $IN(-)$, $T_A = 25^\circ C$, (Note 6), $V_{CM} = 0V$		50	250		50	250	nA
Input Offset Current	$IN(+)$ – $IN(-)$, $T_A = 25^\circ C$		± 5	± 50		± 5	± 50	nA
Input Common-Mode Voltage Range	$V^+ = 30 V_{DC}$, $T_A = 25^\circ C$, (Note 7) (LM2924, $V^+ = 26 V_{DC}$)	0		$V^+ - 1.5$	0		$V^+ - 1.5$	V
Supply Current	$R_L = \infty$, $V^+ = 30V$, (LM2924, $V^+ = 26V$)		1	2		1	2	mA
Supply Current	$R_L = \infty$, $V^+ = 5V$		0.5	1		0.5	1	mA
Amplifier-to-Amplifier Coupling	$f = 1$ kHz to 20 kHz, $T_A = 25^\circ C$, Input Referred, (Note 8)		-100			-100		dB
Input Offset Voltage	(Note 5)			± 7			± 10	mV
Input Bias Current	$IN(+)$ or $IN(-)$			400			500	nA
Input Offset Current	$IN(+)$ – $IN(-)$			150			200	nA
Input Common-Mode Voltage Range	$V^+ = 30 V_{DC}$, (Note 7) (LM2924, $V^+ = 26 V_{DC}$)	0		$V^+ - 2$	0		$V^+ - 2$	V
Differential Input Voltage	Keep All V_{IN} 's $\geq 0 V_{DC}$ (or V^- , if Used), (Note 9)			32			26	V
OP AMP ONLY								
Large Signal Voltage Gain	$V^+ = 15 V_{DC}$, V_o swing = $1 V_{DC}$ to $11 V_{DC}$, $R_L = 2 k\Omega$, $T_A = 25^\circ C$	25	100		25	100		V/mV

Electrical Characteristics ($V^+ = 5 V_{DC}$; specifications apply to both amplifiers unless otherwise stated)
(Note 4) (Continued)

Parameter	Conditions	LM392			LM2924			Units
		Min	Typ	Max	Min	Typ	Max	
OP AMP ONLY								
Output Voltage Swing	$R_L = 2\text{ k}\Omega$, $T_A = 25^\circ\text{C}$, (LM2924, $R_L \geq 10\text{ k}\Omega$)	0		$V^+ - 1.5$	0		$V^+ - 1.5$	V
Common-Mode Rejection Ratio	DC, $T_A = 25^\circ\text{C}$, $V_{CM} = 0 V_{DC}$ to $V^+ - 1.5 V_{DC}$	65	70		50	70		dB
Power Supply Rejection Ratio	DC, $T_A = 25^\circ\text{C}$	65	100		50	100		dB
Output Current Source	$V_{IN(+)} = 1 V_{DC}$, $V_{IN(-)} = 0 V_{DC}$, $V^+ = 15 V_{DC}$, $V_o = 2 V_{DC}$, $T_A = 25^\circ\text{C}$	20	40		20	40		mA
Output Current Sink	$V_{IN(-)} = 1 V_{DC}$, $V_{IN(+)} = 0 V_{DC}$, $V^+ = 15 V_{DC}$, $V_o = 2 V_{DC}$, $T_A = 25^\circ\text{C}$	10	20		10	20		mA
	$V_{IN(-)} = 1 V_{DC}$, $V_{IN(+)} = 0 V_{DC}$, $V^+ = 15 V_{DC}$, $V_o = 200\text{ mV}$, $T_A = 25^\circ\text{C}$	12	50		12	50		μA
Input Offset Voltage Drift	$R_S = 0\Omega$		7			7		$\mu\text{V}/^\circ\text{C}$
Input Offset Current Drift	$R_S = 0\Omega$		10			10		$\text{pA}_{DC}/^\circ\text{C}$
COMPARATOR ONLY								
Voltage Gain	$R_L \geq 15\text{ k}\Omega$, $V^+ = 15 V_{DC}$, $T_A = 25^\circ\text{C}$	50	200		25	100		V/mV
Large Signal Response Time	$V_{IN} = \text{TTL Logic Swing}$, $V_{REF} = 1.4 V_{DC}$, $V_{RL} = 5 V_{DC}$, $R_L = 5.1\text{ k}\Omega$, $T_A = 25^\circ\text{C}$		300			300		ns
Response Time	$V_{RL} = 5 V_{DC}$, $R_L = 5.1\text{ k}\Omega$, $T_A = 25^\circ\text{C}$, (Note 10)		1.3			1.5		μs
Output Sink Current	$V_{IN(-)} = 1 V_{DC}$, $V_{IN(+)} = 0 V_{DC}$, $V_o \geq 1.5 V_{DC}$, $T_A = 25^\circ\text{C}$	6	16		6	16		mA
Saturation Voltage	$V_{IN(-)} \geq 1 V_{DC}$, $V_{IN(+)} = 0$, $I_{SINK} \leq 4\text{ mA}$, $T_A = 25^\circ\text{C}$		250	400		400		mV
	$V_{IN(-)} \geq 1 V_{DC}$, $V_{IN(+)} = 0$, $I_{SINK} \leq 4\text{ mA}$			700		700		mV
Output Leakage Current	$V_{IN(-)} = 0$, $V_{IN(+)} \geq 1 V_{DC}$, $V_o = 5 V_{DC}$, $T_A = 25^\circ\text{C}$		0.1			0.1		nA
	$V_{IN(-)} = 0$, $V_{IN(+)} \geq 1 V_{DC}$, $V_o = 30 V_{DC}$			1.0		1.0		μA

Note 1: For operating at temperatures above 25°C , the LM392 and the LM2924 must be derated based on a 125°C maximum junction temperature and a thermal resistance of $122^\circ\text{C}/\text{W}$ which applies for the device soldered in a printed circuit board, operating in still air ambient. The dissipation is the total of both amplifiers—use external resistors, where possible, to allow the amplifier to saturate or to reduce the power which is dissipated in the integrated circuit.

Note 2: Short circuits from the output to V^+ can cause excessive heating and eventual destruction. When considering short circuits to ground, the maximum output current is approximately 40 mA for the op amp and 30 mA for the comparator independent of the magnitude of V^+ . At values of supply voltage in excess of 15V , continuous short circuits can exceed the power dissipation ratings and cause eventual destruction.

Note 3: This input current will only exist when the voltage at any of the input leads is driven negative. It is due to the collector-base junction of the input PNP transistors becoming forward biased and thereby acting as input diode clamps. In addition to this diode action, there is also lateral NPN parasitic transistor action on the IC chip. This transistor action can cause the output voltages of the amplifiers to go to the V^+ voltage level (or to ground for a large overdrive) for the time duration that an input is driven negative. This is not destructive and normal output states will re-establish when the input voltage, which was negative, again returns to a value greater than -0.3V (at 25°C).

Note 4: These specifications apply for $V^+ = 5V$, unless otherwise stated. For the LM392, temperature specifications are limited to $0^\circ\text{C} \leq T_A \leq +70^\circ\text{C}$ and the LM2924 temperature specifications are limited to $-40^\circ\text{C} \leq T_A \leq +85^\circ\text{C}$.

Note 5: At output switch point, $V_O \approx 1.4V$, $R_S = 0\Omega$ with V^+ from 5V to 30V; and over the full input common-mode range (0V to $V^+ - 1.5V$).

Note 6: The direction of the input current is out of the IC due to the PNP input stage. This current is essentially constant, independent of the state of the output so no loading change exists on the input lines.

Note 7: The input common-mode voltage or either input signal voltage should not be allowed to go negative by more than 0.3V. The upper end of the common-mode voltage range is $V^+ - 1.5V$, but either or both inputs can go to 32V without damage (26V for LM2924).

Note 8: Due to proximity of external components, insure that coupling is not originating via the stray capacitance between these external parts. This typically can be detected as this type of capacitive increases at higher frequencies.

Note 9: Positive excursions of input voltage may exceed the power supply level. As long as the other input voltage remains within the common-mode range, the comparator will provide a proper output state. The input voltage to the op amp should not exceed the power supply level. The input voltage state must not be less than $-0.3V$ (or 0.3V below the magnitude of the negative power supply, if used) on either amplifier.

Note 10: The response time specified is for a 100 mV input step with 5 mV overdrive. For larger overdrive signals 300 ns can be obtained.

Schematic Diagram

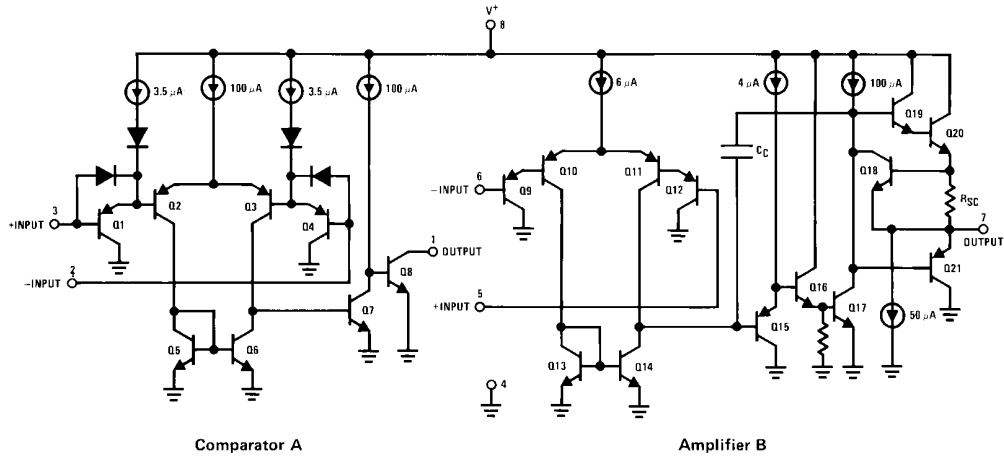

TL/H/7793-2

Application Hints

Please refer to the application hints section of the LM193 and the LM158 datasheets.

Physical Dimensions inches (millimeters)

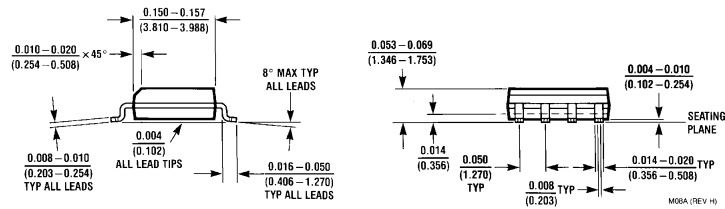
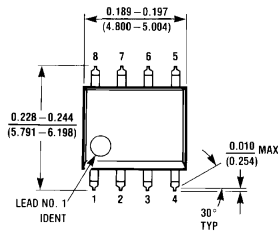

S.O. Package (M)
Order Number LM392M or LM2924M
NS Package Number M08A

Physical Dimensions inches (millimeters) (Continued)

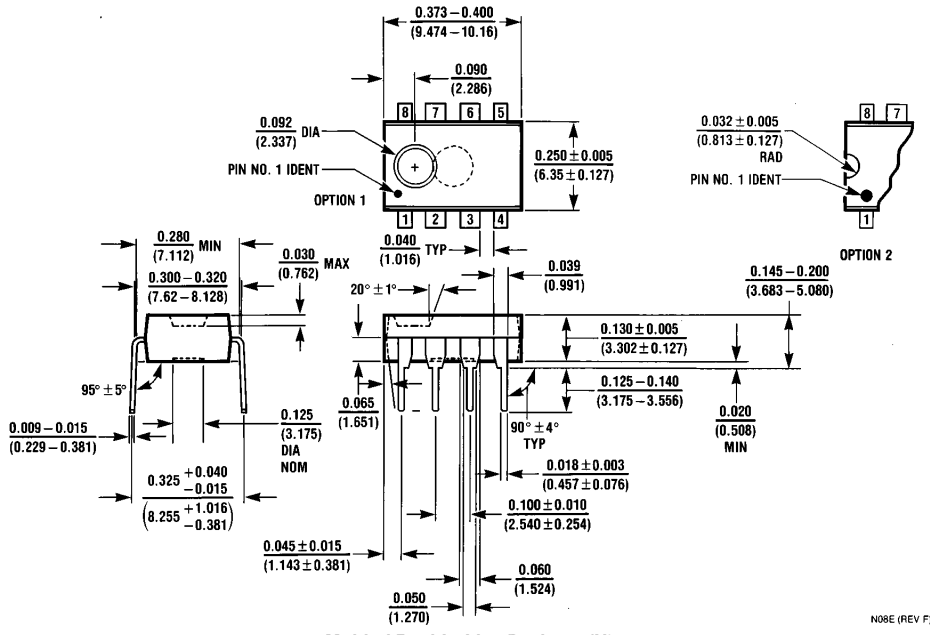

Molded Dual-In-Line Package (N)
Order Number LM392N or LM2924N
NS Package Number N08E

N08E (REV F)

LIFE SUPPORT POLICY

NATIONAL'S PRODUCTS ARE NOT AUTHORIZED FOR USE AS CRITICAL COMPONENTS IN LIFE SUPPORT DEVICES OR SYSTEMS WITHOUT THE EXPRESS WRITTEN APPROVAL OF THE PRESIDENT OF NATIONAL SEMICONDUCTOR CORPORATION. As used herein:

1. Life support devices or systems are devices or systems which, (a) are intended for surgical implant into the body, or (b) support or sustain life, and whose failure to perform, when properly used in accordance with instructions for use provided in the labeling, can be reasonably expected to result in a significant injury to the user.
2. A critical component is any component of a life support device or system whose failure to perform can be reasonably expected to cause the failure of the life support device or system, or to affect its safety or effectiveness.



National Semiconductor Corporation
 1111 West Bardin Road
 Arlington, TX 76017
 Tel: 1(800) 272-9959
 Fax: 1(800) 737-7018

National Semiconductor Europe
 Fax: (+49) 0-180-530 85 86
 Email: cnjwge@tevm2.nsc.com
 Deutsch Tel: (+49) 0-180-530 85 85
 English Tel: (+49) 0-180-532 78 32
 Français Tel: (+49) 0-180-532 93 58
 Italiano Tel: (+49) 0-180-534 16 80

National Semiconductor Hong Kong Ltd.
 19th Floor, Straight Block,
 Ocean Centre, 5 Canton Rd.
 Tsimshatsui, Kowloon
 Hong Kong
 Tel: (852) 2737-1600
 Fax: (852) 2736-9960

National Semiconductor Japan Ltd.
 Tel: 81-043-299-2309
 Fax: 81-043-299-2408

National does not assume any responsibility for use of any circuitry described, no circuit patent licenses are implied and National reserves the right at any time without notice to change said circuitry and specifications.