

LM2879 Dual 8W Audio Amplifier

General Description

The LM2879 is a monolithic dual power amplifier which offers high quality performance for stereo phonographs, tape players, recorders, AM-FM stereo receivers, etc.

The LM2879 will deliver 8W/channel to an 8Ω load. The amplifier is designed to operate with a minimum of external components and contains an internal bias regulator to bias each amplifier. Device overload protection consists of both internal current limit and thermal shutdown.

Features

- A_{VO} typical 90 dB
- 9W per channel (typical)
- 60 dB ripple rejection
- 70 dB channel separation

- Self-centering biasing
- 4 MΩ input impedance
- Internal current limiting
- Internal thermal protection

Applications

- Multi-channel audio systems
- Tape recorders and players
- Movie projectors
- Automotive systems
- Stereo phonographs
- Bridge output stages
- AM-FM radio receivers
- Intercoms
- Servo amplifiers
- Instrument systems

Connection Diagram and Typical Application

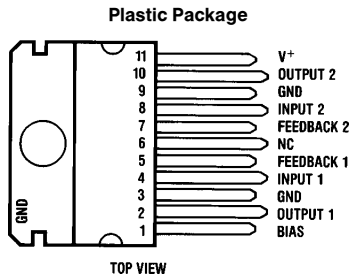

TL/H/5291-1

Order Number LM2879T
See NS Package Number TA11B

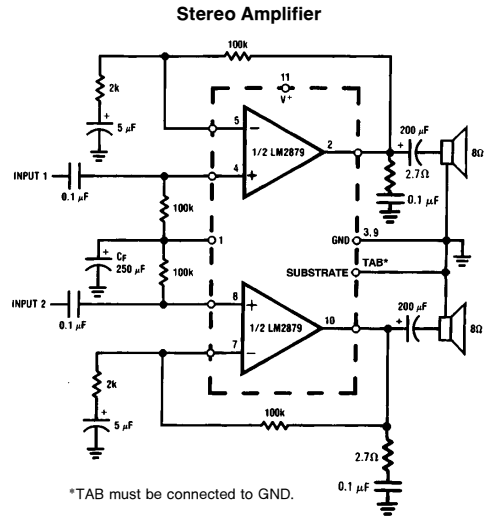

TL/H/5291-2

FIGURE 1

Absolute Maximum Ratings

If Military/Aerospace specified devices are required, please contact the National Semiconductor Sales Office/Distributors for availability and specifications.

Supply Voltage	35V
Input Voltage (Note 1)	±0.7V
Operating Temperature (Note 2)	0°C to +70°C

Storage Temperature	-65°C to +150°C
Junction Temperature	150°C
Lead Temp. (Soldering, 10 seconds)	260°C
ESD rating to be determined.	
Thermal Resistance	
θ_{JC}	1°C/W
θ_{JA}	43°C/W

Electrical Characteristics $V_S = 28V$, $T_{TAB} = 25^\circ C$, $R_L = 8\Omega$, $A_V = 50$ (34 dB), unless otherwise specified.

Parameter	Conditions	Min	Typ	Max	Units
Total Supply Current	$P_O = 0W$		12	65	mA
Operating Supply Voltage		6		32	V
Output Power/Channel	$f = 1 \text{ kHz}$, THD = 10%, $T_{TAB} = 25^\circ C$	6	8		W
Distortion	$f = 1 \text{ kHz}$, $R_L = 8\Omega$ $P_O = 1 \text{ W/Channel}$		0.05	1	%
Output Swing	$R_L = 8\Omega$		$V_S - 6V$		Vp-p
Channel Separation	$C_{BYPASS} = 50 \mu F$, $C_{IN} = 0.1 \mu F$ $f = 1 \text{ kHz}$, Output Referred $V_O = 4 \text{ Vrms}$	-50	-70		dB
PSRR Positive Supply	$C_{BYPASS} = 50 \mu F$, $C_{IN} = 0.1 \mu F$ $f = 120 \text{ Hz}$, Output Referred $V_{ripple} = 1 \text{ Vrms}$	-50	-60		dB
PSRR Negative Supply	Measured at DC, Input Referred		-60		dB
Common-Mode Range	Split Supplies ±15V, Pin 1 Tied to Pin 11		±13.5		V
Input Offset Voltage			10		mV
Noise	Equivalent Input Noise $R_S = 0$, $C_{IN} = 0.1 \mu F$ BW = 20 - 20 kHz CCIR*ARM Output Noise Wideband $R_S = 0$, $C_{IN} = 0.1 \mu F$, $A_V = 200$		2.5 3.0 0.8		μV μV mV
Open Loop Gain	$R_S = 51\Omega$, $f = 1 \text{ kHz}$, $R_L = 8\Omega$		70		dB
Input Bias Current			100		nA
Input Impedance	Open Loop		4		M Ω
DC Output Voltage	$V_S = 28V$		14		V
Slew Rate			2		V/ μs
Power Bandwidth	3 dB Bandwidth at 2.5W		65		kHz
Current Limit			1.5		A

Note 1: The input voltage range is normally limited to ±0.7V with respect to pin 1. This range may be extended by shorting pin 1 to the positive supply.

Note 2: For operation at ambient temperature greater than 25°C, the LM2879 must be derated based on a maximum 150°C junction temperature. Thermal resistance, junction to case, is 3°C/W. Thermal resistance, case to ambient, is 40°C/W.

Typical Performance Characteristics

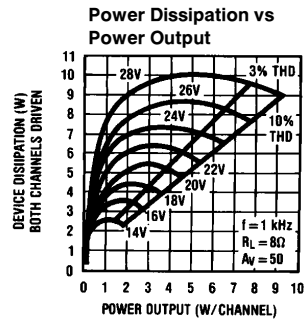
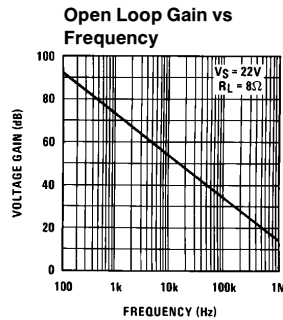
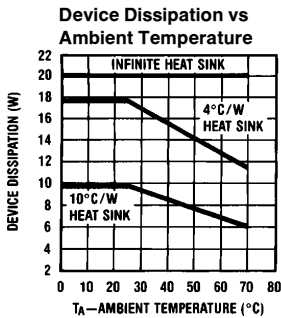

TL/H/5291-3

Typical Performance Characteristics (Continued)

Supply Current vs Output Power

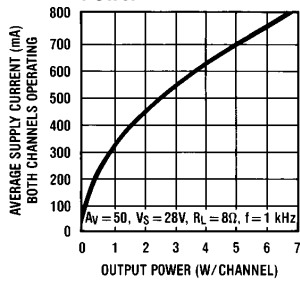

Supply Rejection vs Frequency

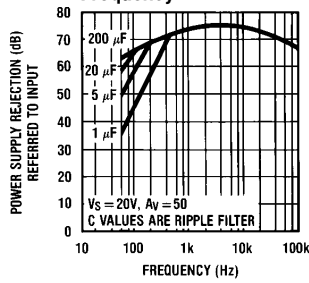

Channel Separation (Referred to the Output) vs Frequency

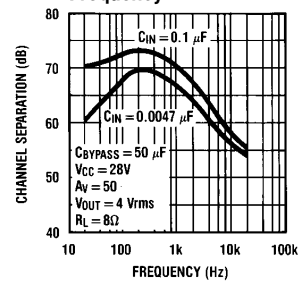

Total Harmonic Distortion vs Frequency

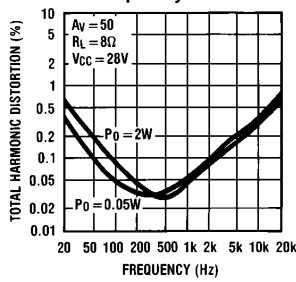

Total Harmonic Distortion vs Frequency

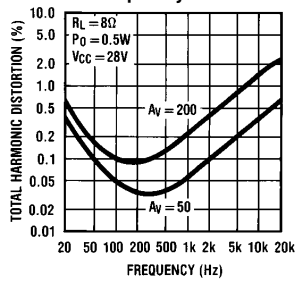

Output Swing vs V_s

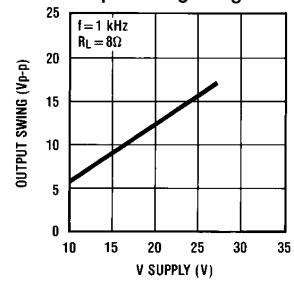

Total Harmonic Distortion vs Power Output

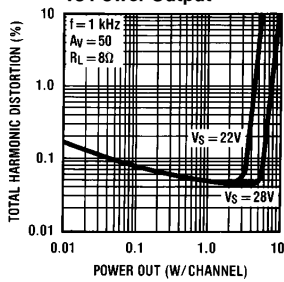

Power Output/Channel vs Supply Voltage

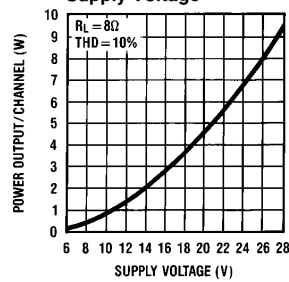

TL/H/5291-4

Equivalent Schematic Diagram

TL/H/5291-5

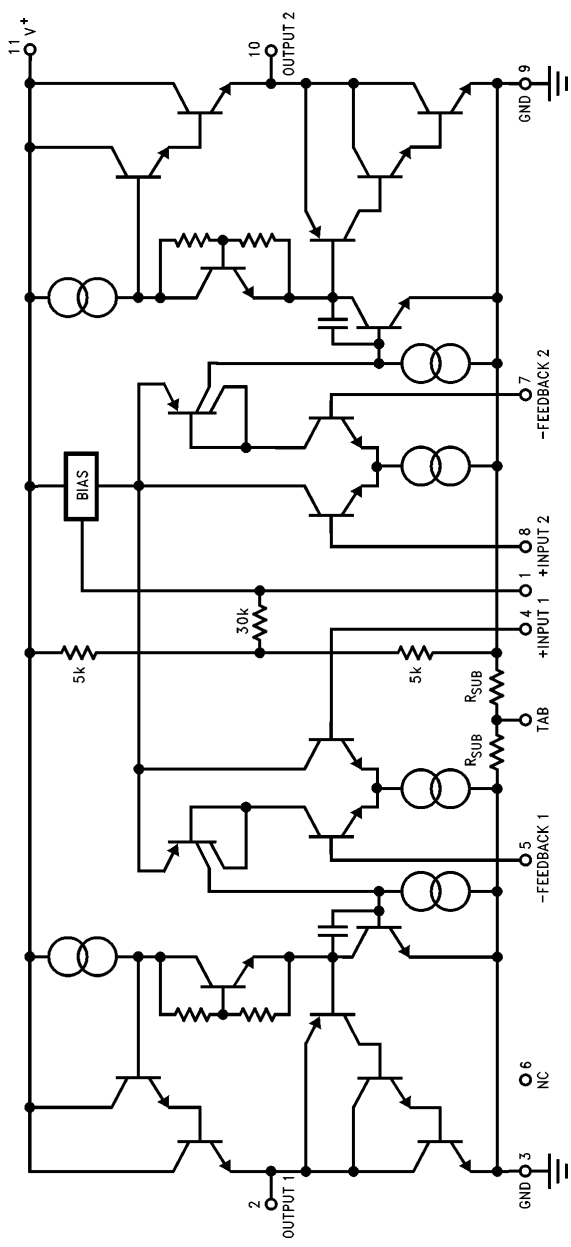

Typical Applications

Two-Phase Motor Drive

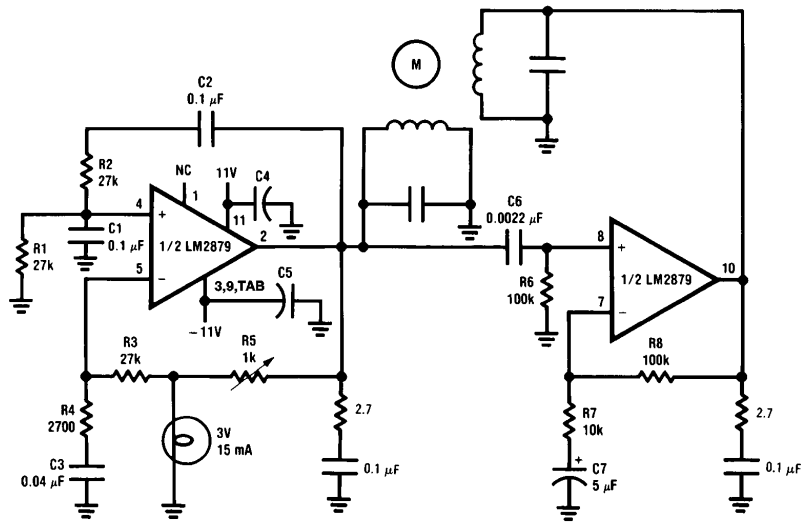

TL/H/5291-6

12W Bridge Amplifier

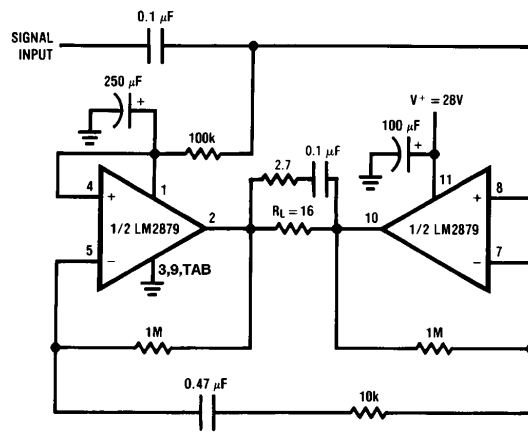

TL/H/5291-7

Typical Applications (Continued)

Simple Stereo Amplifier with Bass Boost

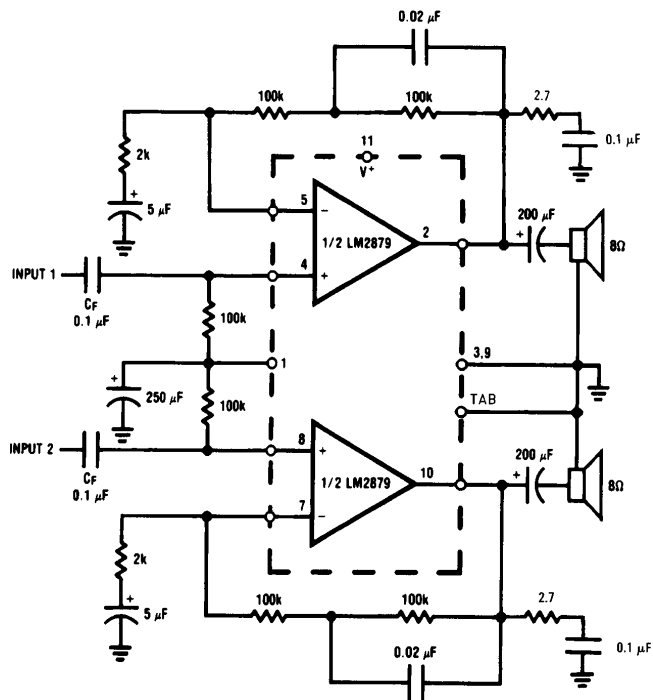

TL/H/5291-8

Power Op Amp (Using Split Supplies)

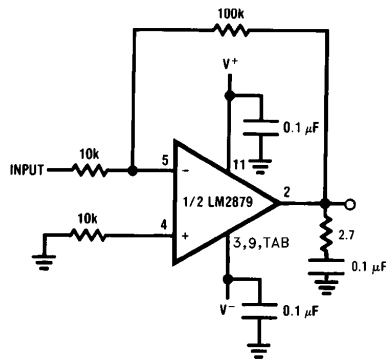

TL/H/5291-9

Typical Applications (Continued)

Stereo Phonograph Amplifier with Bass Tone Control

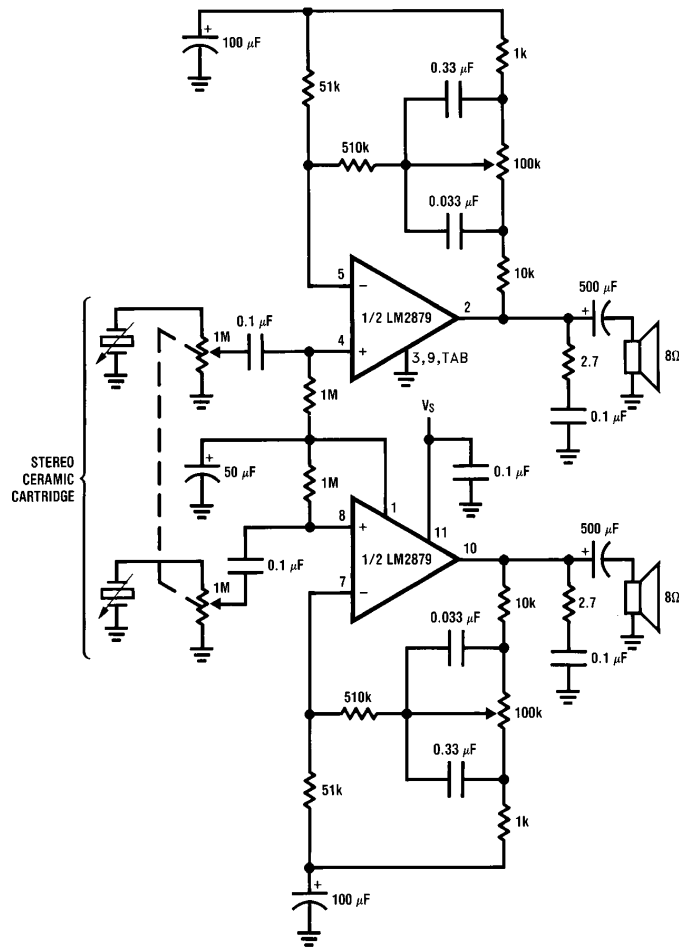

TL/H/5291-10

Frequency Response of Bass Tone Control

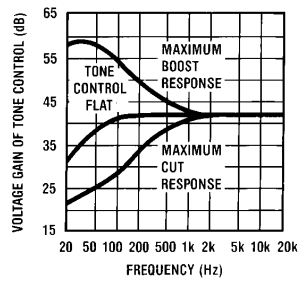

TL/H/5291-11

LM2879 Dual 8W Audio Amplifier

Physical Dimensions inches (millimeters)

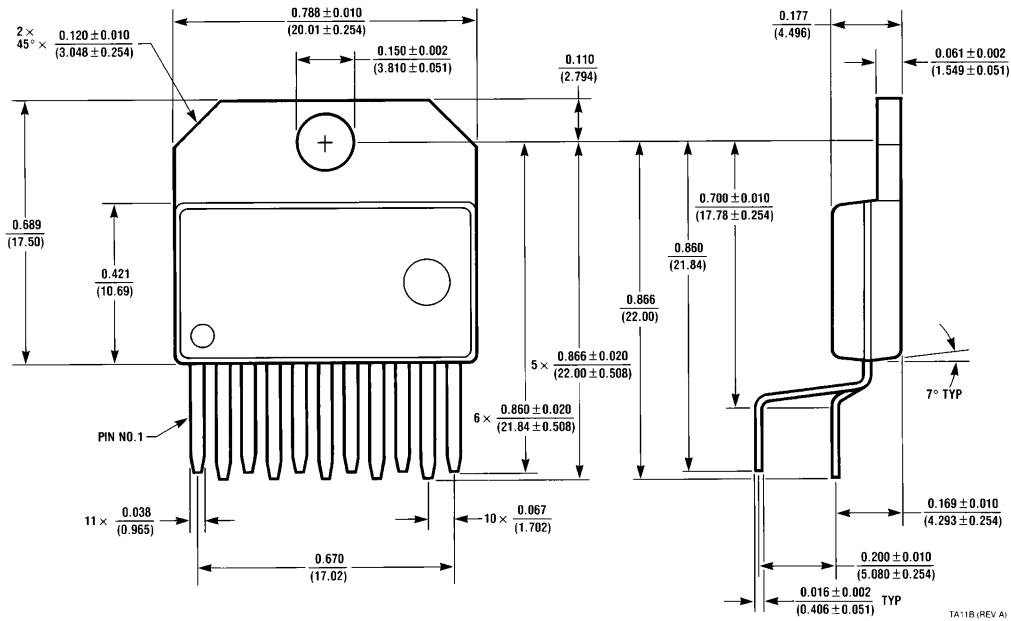

11-Lead TO-220 Power Package (T)
Order Number LM2879T
NS Package Number TA11B

TA11B (REV A)

LIFE SUPPORT POLICY

NATIONAL'S PRODUCTS ARE NOT AUTHORIZED FOR USE AS CRITICAL COMPONENTS IN LIFE SUPPORT DEVICES OR SYSTEMS WITHOUT THE EXPRESS WRITTEN APPROVAL OF THE PRESIDENT OF NATIONAL SEMICONDUCTOR CORPORATION. As used herein:

1. Life support devices or systems are devices or systems which, (a) are intended for surgical implant into the body, or (b) support or sustain life, and whose failure to perform, when properly used in accordance with instructions for use provided in the labeling, can be reasonably expected to result in a significant injury to the user.
2. A critical component is any component of a life support device or system whose failure to perform can be reasonably expected to cause the failure of the life support device or system, or to affect its safety or effectiveness.



National Semiconductor Corporation
 1111 West Bardin Road
 Arlington, TX 76017
 Tel: 1(800) 272-9959
 Fax: 1(800) 737-7018

National Semiconductor Europe
 Fax: (+49) 0-180-530 85 86
 Email: cnjwge@tevm2.nsc.com
 Deutsch Tel: (+49) 0-180-530 85 85
 English Tel: (+49) 0-180-532 78 32
 Français Tel: (+49) 0-180-532 93 58
 Italiano Tel: (+49) 0-180-534 16 80

National Semiconductor Hong Kong Ltd.
 19th Floor, Straight Block,
 Ocean Centre, 5 Canton Rd.
 Tsimshatsui, Kowloon
 Hong Kong
 Tel: (852) 2737-1600
 Fax: (852) 2736-9960

National Semiconductor Japan Ltd.
 Tel: 81-043-299-2309
 Fax: 81-043-299-2408

National does not assume any responsibility for use of any circuitry described, no circuit patent licenses are implied and National reserves the right at any time without notice to change said circuitry and specifications.